



# FG-K SERIES

## Fast Response for Efficient Weighing Applications

The New FG-K series combines fast response time with accurate measurement to suit any weighing application.

- RI-2-3** • **Three weighing resolutions** Normal (1/3000), \*High (1/6000 for 30kg and 60kg weighing capacity) and \*Higher resolution (1/12000 for 60kg and 1/15000 for 30kg and 150kg weighing capacity) \*non NTEP settings



- **Counting function** Useful in piece counting applications with sample size of 5, 10, 20, 50 and 100 pcs for unit weight registration



- **Comparator function** HI / OK / LO comparator indication and optional relay output ( FG-24) for checkweighing applications



- **Calibration function** Simple calibration with external mass



- **Auto-power OFF function** Saves power consumption by automatically switching itself off when the scale displays zero for approx. five minutes

- **Low power supply indication** Alerts user to check AC power supply “Lb1” or batteries “Lb0”

- **Filtering function** Filtering levels of slow, normal and fast are selectable to suit environmental conditions

- **Leveling feet and bubble** Easy to adjust the level of the scale for accurate weighing



- **Optional RS-232C and Comparator Output** Easy to connect peripherals such as printer, comparator light and computer for weighing system applications

### Display Features

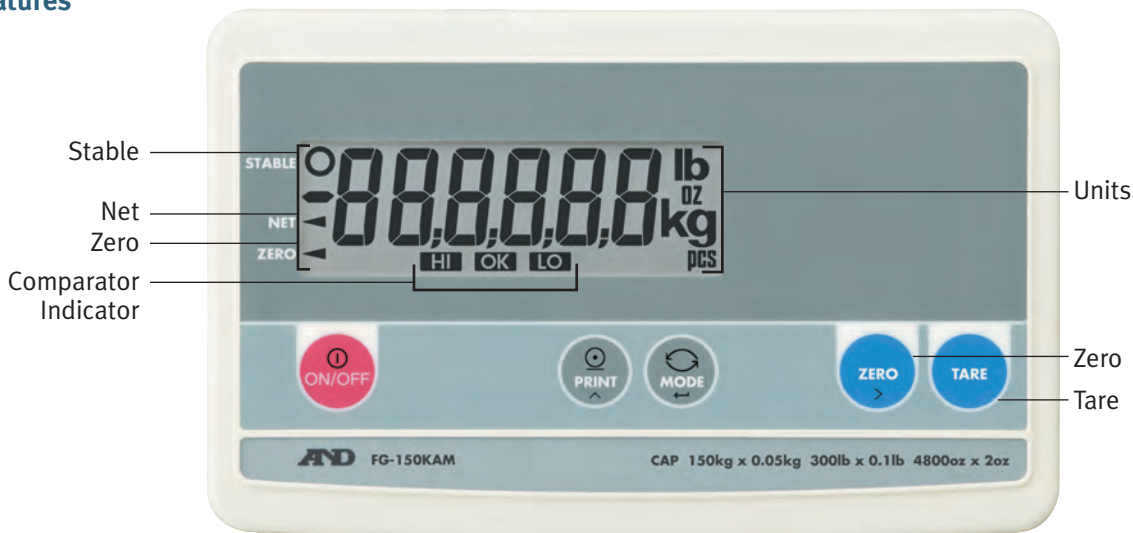



# ROCK SOLID PERFORMANCE

## Low Profile Models

FG-KBM (Medium Pan)

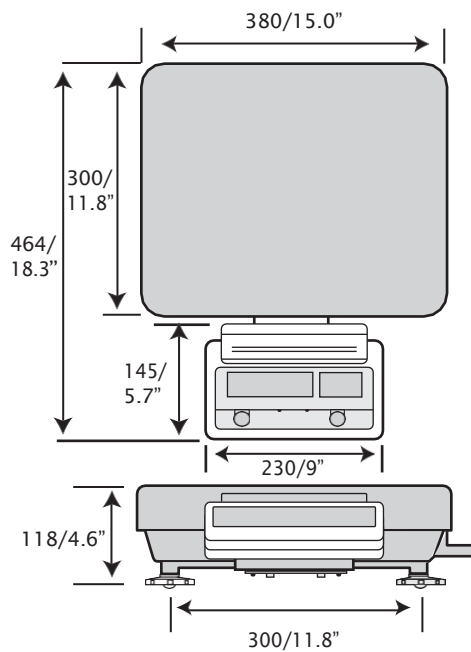

## Column Models

FG-KAM (Medium Pan)

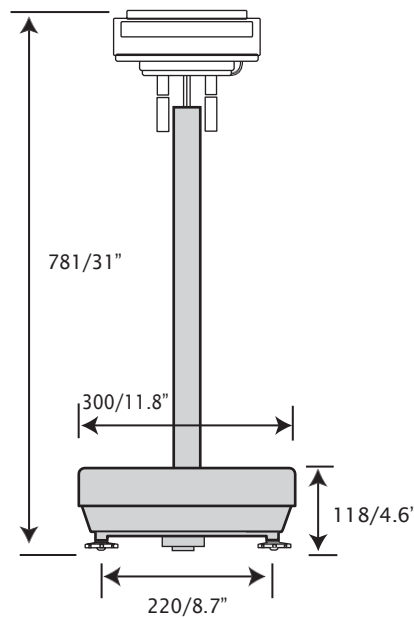

## Column Models

FG-KAL (Large Pan)

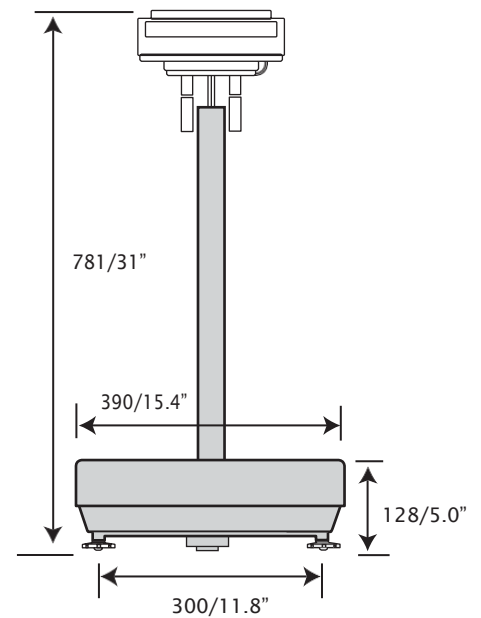

UNIT=mm/in

## Built to last, easy to operate

- One second response time
- Three weighing resolutions
- AC or battery operation
- Stainless steel weigh pan  
M (300 x 380mm), L (390 x 530mm)



FG-30KBM  
FG-60KBM  
FG-150KBM



FG-30KAM  
FG-60KAM  
FG-150KAM



FG-60KAL  
FG-150KAL

# Specifications

	FG-30KAM FG-30KBM	FG-60KAM FG-60KBM	FG-150KAM FG-150KBM	FG-60KAL	FG-150KAL	FG-200KAL
Weight capacity (kg)	30	60	150	60	150	200
Min. display (kg)	0.01*	0.02*	0.05*	0.02*	0.05*	0.05*
	0.005	0.01	0.02	0.01	0.02	0.02
	0.002	0.005	0.01	0.005	0.01	0.01
Weight capacity (lb)	60	150	300	150	300	400
Min. display (lb)	0.02*	0.05*	0.1*	0.05*	0.1*	0.1*
	0.01	0.02	0.05	0.02	0.05	0.05
	0.005	0.01	0.02	0.01	0.02	0.02
Weight capacity (oz)	960	2400	4800	2400	4800	6400
Min. display (oz)	0.5*	1*	2*	1*	2*	2*
	0.2	0.5	1	0.5	1	1
	0.1	0.2	0.5	0.2	0.5	0.5
No. of samples	5 (can be changed to 10, 20, 50 or 100 ) pieces					
Max. counts	120,000 pcs	96,000 pcs	120,000 pcs	96,000 pcs	120,000 pcs	160,000 pcs
Min. unit weight	0.25 g	0.625 g	1.25 g	0.625 g	1.25 g	1.25 g
Repeatability (Std. deviation)	0.05 kg	0.01 kg	0.02 kg	0.01 kg	0.02 kg	0.02 kg
Linearity error	0.01 kg	0.02 kg	0.05 kg	0.02 kg	0.05 kg	0.05 kg
Sensitivity drift	20 ppm /C (10 °C~30 °C / 50 °F~86 °F)					
Display	7 segment LCD display (Character height 26 mm)					
Display update	10 times per second					
Operating temp	-10 °C~40 °C / 14 °F~104 °F, less than 85% RH (no condensation)					
Power supply	AC adapter or C size (R14P / LR14) x 4 batteries					
Battery operating	Approximately 150 hours with alkaline dry cell battery					
Weighing pan size	300 x 380 mm / 11.8 x 15.0 inches			390 x 530 mm / 15.4 x 20.9 inches		
Dimension	FG-KAM: 300(W) x 624(D) x 781(H) mm / FG-KBM: 380(W) x 464(D) x 118(H) mm			390(W) x 771(D) x 781(H) mm		
Weight (approximately)	FG-KAM: 11.2 kg / FG-KBM: 9.7 kg			16.4 kg		
Calibration weight (Factory setting)	30 kg / 60 lb	60 kg / 150 lb	150 kg / 300 lb	60 kg / 150 lb	150 kg / 300 lb	200 kg/400 lb

\* Legal for Trade Setting

## Options

- FG-23 RS-232C serial interface
- FG-24 RS-232C serial interface and comparator relay output
- FG-25 Display Wall Mount Bracket
- FG-26 Carrying Handle

## Accessories

- AD-8121B Dot Matrix Compact Printer
- AD-8118B Universal Printer
- AD-8951 Comparator Light\*  
\*Requires FG-24 and AX-KO1557-W200

## Model Selection Guide

### FG-000K00

Capacity	Column	Pan Size	Model Number
30kg / 60lb	No	M	FG-30KBM
30kg / 60lb	Yes	M	FG-30KAM
60kg / 150lb	No	M	FG-60KBM
60kg / 150lb	Yes	M	FG-60KAM
60kg / 150lb	Yes	L	FG-60KAL
150kg / 300lb	No	M	FG-150KBM
150kg / 300lb	Yes	M	FG-150KAM
150kg / 300lb	Yes	L	FG-150KAL
200kg / 400lb	Yes	L	FG-200KAL



AD-8121B -  
Dot Matrix  
Printer



AD-8951 -  
Light Pole



4180 Silverton Rd NE  
Salem, OR 97304  
(800) 970-7333  
sales@wscmsc.com  
wscmsc.com